

Please, read this manual
carefully before use!

Owner's Manual

Automatic Transfer Switch (ATS)

DOMESTIC	RANGE	CONNECT P/#
ATS-W-80A-1	240 VOLT SINGLE PHASE	MA1-800
ATS-W-95A-3	415 VOLT THREE PHASE	MA3-950



ATS UNIT USE AND SAFETY PRECAUTIONS

Work Area

- Do not use the product near flammable gases, liquids or dust.
- Keep the work area clean and well lit to avoid injuries.
- Keep unauthorized persons, children and animals away from the running product.

Electrical Safety

- The product is energized. Observe safety precautions to avoid electric shock.
- Avoid operating the product in high-humidity environments. Do not allow moisture to enter the product, as this increases the risk of electric shock.
- Avoid direct contact with grounded surfaces (pipes, radiators, etc.).
- Be careful when working with the power cord. Replace it immediately in case of damage, as damaged power cord increases the risk of electric shock.
- All product connections must be carried out by a certified electrician in accordance with all electrical codes and regulations.
- Do not operate the product with your feet in the water, on wet or damp soil.
- Do not touch live parts of the product.
- Keep all electrical equipment dry and clean. Replace damaged or worn wiring. Worn, damaged, or rusted terminals must be replaced as well.

Personal Safety

- Do not operate the product when you are tired or under the influence of potent drugs, alcohol or medication. During operation, inattention can cause serious injury.
- Make sure there are no foreign objects on the product when it is turned on.
- Do not overload the product; use it for its intended purpose only.



PLEASE NOTE!



The total power of power consumers connected to the ATS system must not exceed the maximum permissible power for this ATS unit model.

SPECIFICATIONS

Battery voltage	DC8.0-18V
Power consumption	10W
Operating voltage / Maximum current	Single Phase: ATS-W-80A-1 230-240V 50/60HZ 80A 18kW Three Phase: ATS-W-95A-3 415V 50/60HZ 95A 68kW
Working environment	-20-50 °C humidity: 20-90%
STORAGE ENVIRONMENT	-30-70 °C humidity: 20-90%
Dimensions (mm)	450 x 350 x 200
IP protection class	IP41
Insulation class	AC1.5KV / 1min 1mA

ATS Unit Function

The ATS unit automatically starts the generator and switches over power consumers to it when the main power supply is deenergized.

ATS Operation

When the ATS terminals are disconnected from the main power supply, the ATS unit checks within 12 seconds (time can be programmed) whether there is voltage. If the power supply is not restored, the ATS starts the generator, warms up the engine for 6 seconds (time can be programmed) and supplies power from the generator to power consumers.

When the main power supply is restored, the ATS unit switches over power consumers to the main power supply, and the generator remains operational under no-load condition for another 12 seconds (time can be programmed) to cool the engine and the alternator in order to protect the generator from overheating and deformation.

The ATS unit has an integrated charger to charge the generator battery when the Main power supply is restored.

GENERAL VIEW OF THE ATS UNIT

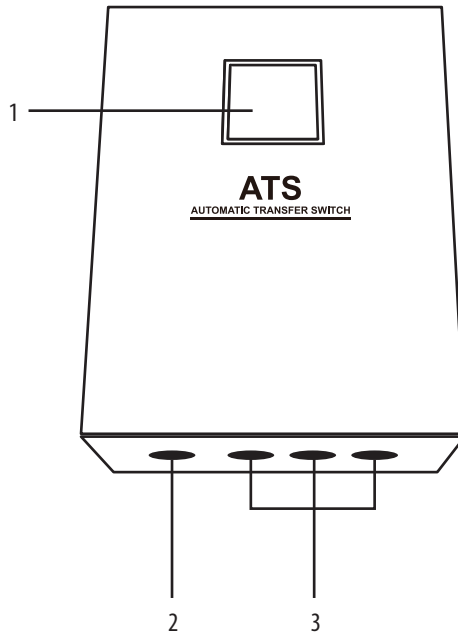

1. Programmable controller
2. Control cable connector (Charger or ATS signal)
3. Cable entry openings

ATS220 ATS Controller Configuration And Instructions Ver1.0

Panel and display

◆ Panel Operation

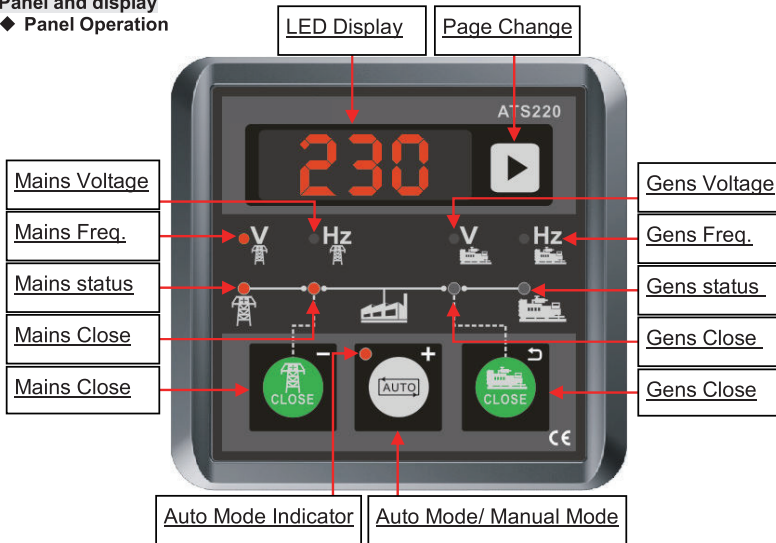

◆ Panel instruction



Indicator name	Mani function
Mains Voltage Indicator	Mains voltage
Mains Frequency Indicator	Mains frequency
Gens Voltage Indicator	Gens voltage
Gens Frequency Indicator	Gens Frequency
Mains status Indicator	LED will be on if the Mains normal and off if Mains off, flash if there is low voltage or high voltage alarm.
Mains Close Indicator	LED will be on if the Mains loading is available.
Gens status Indicator	LED will be on if the Gens normal and off if Gens off, flash if there is low voltage or high voltage alarm.
Gens Close Indicator	LED will be on if the Gens loading is available.
Auto Mode Indicator	LED will be on under auto mode and off under manual mode.

◆ Key Function Description



ICON	Button Name	Function Description
	Mains Close Decrease	<ul style="list-style-type: none"> ◆ Mains loading shall be output under manual mode if press it. ◆ Under display mode, parts of the page can move down. ◆ Under edition mode, to move the digit or decrease the numbers, press the button continuously to reduce the number continuously.
	Auto/manual switching Increase	<ul style="list-style-type: none"> ◆ Press it, working under auto mode if LED is on. ◆ Press it, working under manual mode if LED is off ◆ Under display mode, parts of the page can move up. ◆ Under edition mode, to move the digit or increase the numbers, press the button continuously to increase the number continuously..
	Gens Close Revert	<ul style="list-style-type: none"> ◆ Gens loading shall be output under manual mode if press it. ◆ Under edition mode, pressing this key can cancel the setting and back to upper class under edition. ◆ Under display mode, pressing this key ,Parameters to be saved under value checking page.
	Page Change Confirm	<ul style="list-style-type: none"> ◆ Change the display page. ◆ Under display mode,Confirm entering parameter edition mode. ◆ Under edition mode, Confirm the change.

Control and operation instruction

◆ Mode change

Manual and Auto modes are available for this controller, press  to switch; when the LED is lighted like this , it means working under auto mode. When the LED is lighted like this , it means working under Manual mode,

◆ Manual Mode

When press  and indicator is off, then it means working under Manual mode. Under manual mode, Mains loading shall be output under manual mode if press . Gens loading shall be output under manual mode if press . There is no output for genset crank relay.

◆ Auto mode

When press  and indicator is on, then it means working under Auto mode. Under Auto Mode:

When the Mains becomes abnormal (power shortage, over voltage, under voltage), then "Mains abnormal delay" starts, "Gens Start Delay" shall also start if the Mains is still abnormal after the delay, then Gens relay output shall be closed and start to crank. When the gens voltage becomes normal, "Gens normal delay" starts. The ATS switch will transfer to Gens when the Gens loading output closed after "Transfer interval delay".

When the Mains becomes normal, then "Mains normal delay" starts, Gens loading relay is off, the ATS switch transfer to Mains when the Mains loading is closed after "Transfer interval delay".

When the Mains is normal, then "Gens Stop Delay" starts, the genset shall be stop after gens crank relay is off after delay.



Note: the default mode is Manual mode, Auto indicator is off.











Warning: please make sure that the controller is under manual mode if you are going to maintain the equipment in order to avoid any accidents.

Parameters setting

◆ Edition Page



Please operate as below steps:

1. Press  and  simultaneously, then loose, Then system comes into menu setting.
2. Under display mode, Press to  shift down the parameters, press  to shift up the parameters, press to get into parameter changing page.
3. Under display mode, press  to get into parameter changing page, this option's last digit become flashed, then it means entering the edition page.
4. Under edition mode, Press  to add number, press  to reduce number, press  to cancel. The value can be increased or decreased continuously when pressing the button continuously.
5. After correction, Press  to confirm the value modification, this option's last digit become flashed, then it comes into display mode.

6. Under edition mode, press  to cancel correction and revert back to display mode.

7. Under display mode, press  to exit and save data.

 **Note:** Please press  and  on the mean time, then press  in order to make all the parameters to be default status.

 **Note:** the data can not be saved if the user didn't press  to confirm the setting.

 **Warning:** it will be valid once setting ok, please take care safety.

◆ **Parameter setting**

No.	Parameter	Range(default)	Notes
0	Mains Normal Delay	0-6500s(10s)	It is the delay of Mains from voltage abnormal to voltage normal.
1	Mains Abnormal Delay	0-6500s(5s)	It is the delay of Mains from voltage normal to voltage abnormal.
2	Gens Normal Delay	0-6500s(10s)	It is the delay of Gens from voltage abnormal to voltage normal.
3	Gens Start Delay	0-6500s(1s)	When Mains voltage is abnormal, start delay begins; start signal is initiated after the delay has expired.
4	Gens Stop Delay	0-6500s(5s)	When starting, if the Mains voltage is normal, stop delay begins; stop signal is initiated after the delay has expired.
5	Close Delay	1.0-10.0s(10.0s)	Closing relay output pulse. If set as 10S, it is continuous output.
6	Transfer interval delay	0-3600.0s(1.0s)	It is the interval time for Mains loading to Gens or Gens loading to Mains when the setting is loading continuously.
7	Exceed Transfer	0-20s(20s)	It is the extra output delay of the close relay after the closing signal has received. If the parameter is 20s, the relay will continue to output.
8	Mains under voltage	55-330V(184V)	if the Mains voltage is lower than "Mains under voltage" and during "Mains Abnormal Delay" still lower than "Mains under voltage" after delay, then it regards as Mains abnormal. if during "Mains Abnormal Delay", the mains voltage up is higher than "Mains Revert under voltage", then it is regards as Mains normal.
9	Mains Revert under voltage	55-330V(207V)	
10	Mains over voltage	55-330V(276V)	If the Mains voltage is higher than "Mains over voltage" and during "Mains Abnormal Delay" still higher than "Mains over voltage" after delay, then it regards as Mains abnormal. If during "Mains Abnormal Delay", the Mains voltage down is lower than "Mains Revert over voltage", then it is regards as Mains normal.
11	Mains Revert over voltage	55-330V(253V)	
12	Gens Over Frequency	40-80.0Hz (57.0Hz)	Gens frequency upper limit, it is abnormal when the gens frequency has exceed the set value.
13	Gens Under Frequency	0-70.0Hz (40.0Hz)	Gens frequency lower limit, it is normal when the gens frequency has exceed the set value.
14	Gens Over voltage	0-360V(264V)	Gens voltage upper limit, it is normal when the gens voltage has fallen below the set value.

15	Gens Under voltage	0-360V(192V)	Gens voltage lower limit,it is abnormal when the gens voltage has fallen below the set value.
16	Close Input Enable	0- Disable 1- Enable	When the loading input starts, the status will be shown by the indicator on the panel according to the input parameter,or it will be lighted by the Mains or Gens loading relay outputs.
17	Remote Start Input Type	0-Remote Start Is On load 1-Remote Start Is Off load 2-Simulated mains	Remote Start Is On load: The generator will start, and the load transferred to the generator when the remote start is active. Remote Start Is Off load: The generator will start and run off load when the remote start input is active. Simulated mains: If the input is active the generator will not start in the event of a mains failure.

OPERATION PANEL

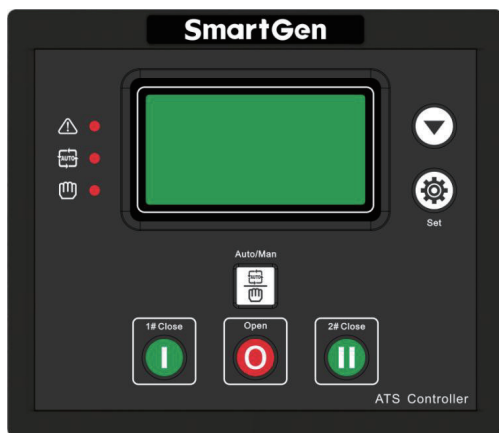



KEY FUNCTION DESCRIPTION

	I# Manual Close	In Manual mode, switch on 1# power to load.
	Open	In Manual mode, switch off 1# or 2# power to off-load.
	II# Manual Close	In Manual mode, switch on 2# power to load.
	Manual/Auto Set	Press the button and controller enter into Manual or Auto mode.
	Menu /Confirm	Press the button to enter into menu interface; pressing and holding it to return to the main menu interface. When an alarm occurs, pressing and holding the button for more than 3s can remove alarm.
	Scroll Screen /Increase	Scroll the screen. In parameter setting, pressing this button can decrease values. Pressing and holding the button for more than 3s, there is a flash on the backlight to confirm the “always illuminated” mode is selected. Pressing and holding the button for more than 3s again, the backlight will extinguished which means the “normal display” mode is selected.

LCD DISPLAY

MAIN SCREEN

<p>U1(L-L) 380 380 380V U2(L-L) 380 380 380V F1 50.0Hz F2 50.0Hz Present Status: MANUAL </p>	<p>This screen shows: 1#/2# line voltage (L1-L2, L2-L3, and L3-L1), frequency, controller's working status, close/open information and load information.</p>
<p>U1(L-N) 220 220 220V U2(L-N) 220 220 220V 2016-06-27 (1) 09:43:36 Present Status: MANUAL </p>	<p>This screen shows: 1# and 2# 3 phase Voltage (L-N), real-time clock, controller's working status, close/open information and load information.</p>
<p>1# Under Volt 2# Volt normal Gens Start signal Out Present Status: AUTO </p>	<p>First line: 1# working status Second line: 2# working status Third line: other working status Fourth line: alarm type and information. Fifth line: close/open information and load information</p>

Display of the #1 status (upper to lower)

No.	Item	Type	Description
1	1# Gens Alarm	Alarm	When 1# genset failure occurs, this will display.
2	1# Fail to Close	Alarm	When 1# close failure occurs, this will display.
3	1# Fail to Open	Alarm	When 1# open failure occurs, this will display.
4	1# Over Voltage	Indication	When 1# power supply voltage has exceeded the set value, this will display.
5	1# Loss of Phase	Indication	Loss of any phase of A, B and C.
6	1# Over Freq	Indication	When 1# power supply frequency is higher than the set value, this will display.
7	1# Under Freq	Indication	When 1# power supply frequency has fallen below the set value, this will display.
8	1# Under Volt	Indication	When 1# power supply voltage has fallen below the set value, this will display.
9	1# Phase Sequence Wrong	Warning	Phase sequence is not A-B-C.
10	1# Volt Normal	Indication	1# power supply voltage is within the setting range.

Display of the #2 status (upper to lower)

No.	Item	Type	Description
1	2# Gens Alarm	Alarm	When 2# genset failure occurs, this will display.
2	2# Fail to Close	Alarm	When 2# close failure occurs, this will display.
3	2# Fail to Open	Alarm	When 2# open failure occurs, this will display.
4	2# Over Voltage	Indication	When 2# power supply voltage has exceeded the setting value, this will display.
5	2# Loss of Phase	Indication	Loss of any phase of A, B and C.
6	2# Over Freq	Indication	When 2# power supply frequency is higher than the set value, this will display.
7	2# Under Freq	Indication	When 2# power supply frequency has fallen below the set value, this will display.
8	2# Under Volt	Indication	When 2# power supply voltage has fallen below the set value, this will display.
9	2# Phase Sequence Wrong	Warning	Phase sequence is not A-B-C.
10	2# Volt Normal	Indication	2# power supply voltage is within the setting range.

Display status of the other items (upper to lower)

No.	Item	Type	Description
1	Trip Alarm	Alarm	Trip alarm input is active.
2	Breaking Compulsorily	Warning	Breaking compulsorily input is active.
3	Gens Start Out	Indication	Start input is active.
4	Remote Start Input	Indication	This input is active when start the genset circularly.

NOTE:

Alarm: When alarm occurs, indicators will flash and this alarm signal won't be removed until long pressing  to reset.

Warning: When warning alarm occurs, alarm indicator will flash while extinguish when warning alarm is inactive. That is to say, warning alarm is not latched.

MA3-950 CIRCUIT DIAGRAM

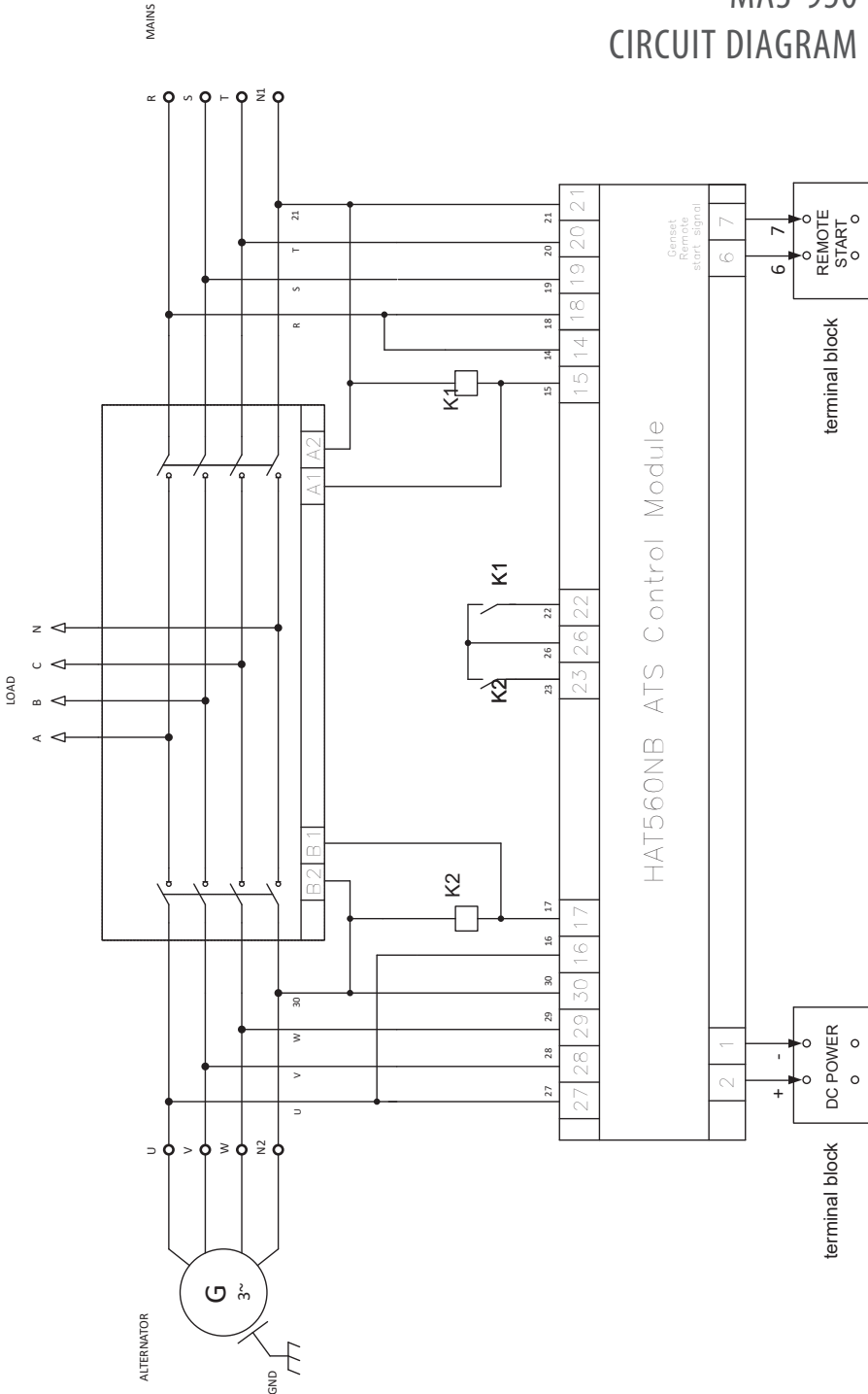

Connection of the generator and ATS to the building power supply network:

CONNECTION DIAGRAM

