

**MAXWATT**  
POWER WHEN YOU NEED IT



*Operators  
Manual Gasoline  
Water Pump*

## TABLE OF CONTENTS

---

| <u>CHAPTER</u>                                     | <u>PAGE</u> |
|--|-------------|
| IMPORTANT.....                                     | 1           |
| CHAPTER 1 – INSTRUCTIONS TO OPEN PACKAGE.....      | 3           |
| CHAPTER 2 – SAFETY RULES.....                      | 4-5         |
| CHAPTER 3 – PRODUCT STRUCTURE AND DESCRIPTION..... | 6-7         |
| CHAPTER 4 – MAIN PARAMETERS.....                   | 8           |
| CHAPTER 5 – USE AND OPERATION.....                 | 9-12        |
| CHAPTER 6 – REPAIR AND MAINTENANCE.....            | 13          |
| CHAPTER 7 – TROUBLE SHOOTING.....                  | 14-15       |
| CHAPTER 8 – TRANSPORTATION AND STORAGE.....        | 16          |
| CHAPTER 9 – WARRANTY DESCRIPTIONS.....             | 17          |

## ABOUT YOUR WATER PUMP

Thank you for purchasing a MAXWATT Water Pump, (hereinafter referred to as “the water pump”).

This water pump is suitable for use on various trade worksites, whether residential or commercial.

Please read and understand this manual for instructions on start-up, shut down, operations, adjustments, maintenance as well as safety guidelines before using this product. Please take all possible precautions to protect your own safety and that of the people in the immediate vicinity. This manual is the latest version. Save this manual for future reference.

The manufacturer shall not assume any liability for incorrect information contained in this manual.



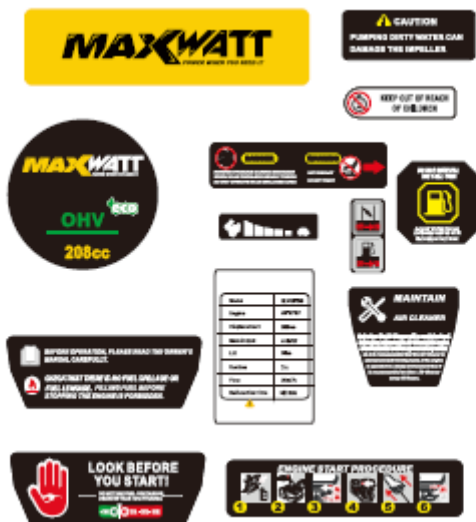

This manual is an essential and important tool for the use of the water pump. When the water pump is transferred to new owners, the manual must be given to the new owners as well.

Some important information in this manual will be indicated in the following way. The owner/user must pay special attention to these instructions.

MAXWATT is constantly improving its products. All information supplied in this manual is based on the latest product information available at the time of printing. The specifications outlined herein are subject to change without notice or obligation. The purchaser and/or user shall assume liability for any modification and/or alterations of this equipment from original design or manufacture.



## HAZARD SIGNAL WORD DEFINITIONS

|  |  |
|--|--|
|                 | Indicates an imminently hazardous situation which, if not avoided, will result in death or serious injury. Obey all safety messages that follow this symbol to avoid possible injury or death. |
|  <b>DANGER</b>  | Indicates an imminently hazardous situation which, if not avoided, will result in death or serious injury.   |
|  <b>WARNING</b> | Indicates a potentially hazardous situation which, if not avoided, could result in death or serious injury.  |
|  <b>CAUTION</b> | Indicates a potentially hazardous situation which, if not avoided, may result in minor or moderate injury.   |
| <b>CAUTION</b>   | Used without the safety alert symbol indicates a potentially hazardous situation which, if not avoided, may result in property damage.   |

For any queries on the above, please contact Gentech Industries, the official service agent for all MAXWATT water pumps and water pumps.

The range of MAXWATT water pumps is safe and reliable, but incorrect usage of these products may cause personal injury and damage to the machine.

As this product is continuously improved and upgraded, the manufacturer reserves the right to modify this manual without notice.

In order to operate the water pump safely, strictly adhere to the operator's manual and please read it through carefully and thoroughly before using the water pump.

### **BEFORE STARTING**

#### **UNPACKING AND DELIVERY INSPECTION**

You should inspect the water pump immediately after you receive delivery thereof. If you have any missing parts, please contact your place of purchase. DO NOT attempt to operate the water pump if there are any missing parts.

The water pump is shipped without oil. You must add an adequate amount of engine oil before using it for the first time. The engine will be damaged beyond repair if it is started without oil. For oil type, please see "Recommended Oil Type" section of this manual on page 9. Fresh regular RON 91 fuel must be used in this unit. DO NOT use Premium or Ethanol based fuels.

### **SAFETY SIGNS**

Comply with the instructions provided by the safety signs and symbols fitted to the water pump and in this manual. The water pump and manual only feature the symbols relevant to the model purchased. Check that the symbols and signs affixed to the unit are always present and legible, otherwise fit replacements in the original positions.

### **GENERAL WARNINGS & DISCLAIMER**

READ and UNDERSTAND this manual completely before using the engine. Failure to properly set up, operate and maintain this engine could result in serious injury or death from carbon monoxide poisoning, electric shock, fire/explosions and/or burns.

In particular be aware of the following hazards:

### **CD POISONING**

Engines give off carbon monoxide, an odourless, colourless poisonous gas that can kill you. You CANNOT smell it, see it or taste it. ONLY run an engine OUTDOORS and AWAY from building air intakes. NEVER run an engine inside any enclosed or semi-enclosed spaces, including homes, basements, garages, sheds, boxes, RV's, boats or pick-up truck beds. These spaces can trap poisonous gases, EVEN if you run a fan or open windows.

### **HEAT**

Unintentional sparks can cause/result in fire or electric shock.

### **FIRE/ EXPLOSION**

OPERATE ONLY in an area with adequate cooling ventilation so the engine does not overheat. The exhaust can be extremely hot. Keep the muffler at least 3 metres from all combustible objects.

All fuels are flammable. Never fuel a running or hot engine. Never pump fuel directly into the engine at a petrol station – use an approved container to transfer the fuel. Ensure that there are no fuel leaks and keep sources of sparks and flames away. Wait for the engine to be cool before fuelling. ALWAYS keep a fire extinguisher rated “ABC” nearby.

### **INSPECT COMPONENTS**

Closely inspect to make sure that there are not any components missing or damaged.

### **GENERAL SAFETY RULES FOR OPERATION**

|  |  |
|--|--|
|  <b>WARNING</b> | <b>Read all safety warnings, instructions, illustrations and specifications provided with this water pump. Failure to follow all instructions listed below may result in electric shock, fire and/or injury.</b> |
|--|--|

**Save all warnings and instructions for future reference.**

This equipment is to be used for the purpose for which it is designed and intended.

Seek assistance if required when moving or lifting the water pump.

### **WORK AREA SAFETY**

- Intended for outdoor use only. DO NOT operate in confined spaces or indoors as carbon monoxide released from the exhaust can kill.
- DO NOT operate in explosive atmospheres such as in the presence of flammable liquids, gases or dust.
- Keep children and bystanders away while operating a water pump.

**Distractions can cause you to lose control.**

- Keep your work area clean and well lit. Cluttered benches and dark areas invite accidents.

- Exposure to rain, damp conditions or extreme temperatures can cause damage or serious injury.

## **PERSONAL SAFETY**

- Stay alert, watch what you are doing and use common sense when operating a water pump.
- DO NOT use a water pump while you are tired or under the influence of drugs, alcohol or medication. A moment of inattention may result in serious personal injury.
- Use personal protection equipment. Always wear eye protection. Wear approved safety impact eye goggles, dust mask, non-skid safety shoes, hard hat and hearing protection for appropriate conditions.
- DO NOT overreach. Keep proper footing and balance at all times. This enables better control of the water pump in unexpected situations.
- Dress properly. DO NOT wear loose clothing, gloves, neckties or jewellery. Keep your hair and clothing away from moving parts. Loose clothes, jewellery or long hair can be caught in moving parts.
- DO NOT let familiarity gained from frequent use of the water pump allow you to become complacent and ignore safety principles and rules. A careless action can cause severe injury within a fraction of a second.
- For your own safety, do not operate your water pump until it is completely assembled and installed according to the instructions and until you have read and understood all of the instructions.

## **WATER PUMP SAFETY RULES**

- DO NOT use the water pump if the engine switch does not turn it on and off. Any water pumps that cannot be controlled with the switch is dangerous and must be repaired.
- Know how to stop the water pump without hesitation. Be thoroughly familiar with proper use of the equipment and all engine controls, output receptacles and connections. Know how to stop the engine quickly (see “Stopping the Water Pump”).
- The engine owner must instruct all operators in safe engine set-up and operation. Only trained adults should set up and operate the engine. DO NOT let children operate it.
- Carefully read about and understand the intended use of this engine. DO NOT use for other purposes as unforeseen hazards or equipment damage may result.
- NEVER operate or let anyone else operate the engine while under the influence of alcohol, drugs or medication.
- DO NOT operate the engine unless all safety covers, guards and barriers are in place and in good working order – and that all controls are properly adjusted for safe operation.
- DO NOT operate the water pump with damaged, missing or broken parts.

- DO NOT modify the water pump in any way. Modifications can create hazards and will also void the warranty.
- NEVER attempt to modify the water pump speed setting. The water pump speed is present for safe and optimal performance of the water pump. If speed needs adjusting, it must be done by factory personnel.
- NEVER attempt to connect external fuel sources in order to increase the water pump run time. A larger tank at pressure or higher elevation will cause a leak from the carburettor during operation. A fire and/or an explosion could result.
- Always turn off the water pump and remove the spark plug(s) or spark plug wire(s) before working on the water pump to prevent accidental starting. Always discharge the capacitor before working on the water pump head to prevent electrical shock. (See Maintenance & Repair section of this manual for instructions on how to do this.)
- The running water pump gives off carbon monoxide, a poisonous gas that can kill you. You CANNOT smell it, see it, or taste it. Follow all instructions for site selection and positioning of the water pump and avoid inhaling fumes from the exhaust. If you start to feel sick, dizzy or weak while using the water pump, shut off the water pump and get to fresh air RIGHT AWAY. See a doctor. You may have carbon monoxide poisoning.
- Immediately turn off the water pump if any of the following conditions arise during operation:
  1. Excessive change in enginespeed, slow or fast;
  2. Sparking or arcs;
  3. Engine misfire;
  4. Excessive vibration;
  5. Flame or smoke or
  6. Abnormal noise
- This product contains or emits chemical known to the Commonwealth of Australia to cause cancer, birth defects or other reproductive harm. Avoid inhalation of exhaust.
- DO NOT operate the engine or handle any electrical equipment while standing in water, while barefoot, while hands are wet or while in the rain or snow. An electric shock may result.
- Avoid contact with bare wires, terminals, connections, etc. while the water pump is running.
- If an electric shock accident occurs, immediately shut down the source of electrical power. If this is not possible, attempt to free the victim from the live conductor. Avoid direct contact with the victim. Use a non- conducting implement, such as a dry rope or board, to free the victim from the live conductor. Administer/apply applicable first aid and get immediate medical help.
- Never smoke near the running engine and never operate near sources of sparks or flames.

## **SERVICE**

- Have your water pump serviced by a qualified repair person using only factory approved replacement parts. This will ensure that the safety of the water pump is maintained. Incorrectly fitted parts will void your warranty.
- The equipment may only be used, maintained or repaired by those persons who understand and have been instructed about the potential dangers. Independent changes in the equipment cancel any manufacturer's liability for any damages that result from these changes.

## **APPROPRIATE USE**

- Use the equipment only when it is in technically perfect condition and only for appropriate jobs, with an awareness of safety and possible dangers, based on observation of the operating instructions. In particular, problems which could influence the operational safety must be dealt with immediately.
- All of the manufacture's safety, work and maintenance regulations as well as the given norms in the Technical Data must be observed.

## **STATIC ELECTRICITY AND FILLING THE PETROL TANK**

Static electricity can initiate from un-grounded petrol tanks or containers from flowing petrol and persons carrying a static electric charge. Static electricity can explosively ignite petrol vapours that are present during the fuelling process, resulting in serious burns to nearby persons.

Many objects can accumulate and retain a static electric charge. Objects made of non-conductive materials (eg. plastics) easily accumulate and retain static electrical charge, as can objects made of conductive material (eg. metal, water) if they are not electrically grounded.

To avoid static electricity while fuelling, certain steps must be followed before and during the fuelling process in order to minimise and safely dissipate static charge build-up:

- Touch a grounded metal object before starting. Always dissipate static charge from your body before beginning the fuelling process by touching a grounded metal object at a safe distance away from the fuel source.
- Use a portable container to fill the tank. NEVER fill the engine's petrol tank directly from the fuel pump – the engine's tank is not grounded and the high velocity flow of petrol from a fuel pump can cause static electric build-up. Use an approved portable container to transfer to the engine's tank.

## **TYPICAL SOURCES OF STATIC ELECTRIC HAZARDS DURING FUELLING**

The following objects can accumulate a static electric charge and cause an ignition spark in typical fuelling situations:

- Ungrounded tanks/containers.



Any ungrounded fuel tank or container can accumulate a static electric charge as a result of contact with other objects or friction during transportation. This static electricity can discharge as a spark to the grounded petrol dispenser nozzle as the nozzle is first brought close to the tank/container at the beginning of the fuelling process.

- Flowing petrol. Most people are not aware that petrol accumulates static electric charge while flowing through a hose or pipe. This charge then transfers to and accumulates in the gas tank or container that is being filled. The total amount of charge accumulation depends on the amount of gas pumped into the container, the speed with which it is pumped, and whether or not the tank/ container is grounded. If sufficient static electric charge accumulates in the fuel tank or container during the fuelling process, the tank/container may discharge a spark to the grounded petrol dispenser nozzle.
- A person dispensing the petrol can carry a static electric charge on their body, typically resulting from contact with their car seat or electronics. The static electricity can discharge a spark between that person's hand and either the grounded dispenser nozzle or the fuel tank opening.
- Before using the water pump, you must select a suitable OUTDOOR location for installation and operation that meets the following criteria:

#### **DRY, LEVEL SURFACE**

The water pump should be positioned on a dry, firm and level surface. Ensure that the water pump sits level and will not slide or shift during operation.

#### **OUTDOORS ONLY**

Follow the directions below for choosing a location to operate your water pump in order to avoid carbon monoxide poisoning:

- The location you choose to operate the water pump must be OUTDOORS and away from all building air intakes.
- Never run the water pump inside any closed or semi-enclosed spaces (even if outdoors), including homes, garages, basements, sheds or boxes. These spaces can trap poisonous gases, even if you run a fan or open windows.
- Ensure that working, battery-operated or battery back-up carbon monoxide alarms are used in any dwelling/structure that is in close proximity to the running operator.



#### **WARNING**

The exhaust from your water pump contains carbon monoxide (CO), a poisonous gas that can kill. You cannot smell it, see it or taste it. Breathing carbon monoxide can cause loss of consciousness and may lead to death. Never run your water pump in a closed or even partially enclosed areas or near open windows or doors. Never attempt to attach ductwork to the muffler system to allow for installation inside an enclosure. This could cause hot air, heat build up and increased exhaust back pressure, resulting in possible exhaust leakage or damage to the water pump.

#### **ADEQUATE COOLING VENTILATION**

The water pump needs adequate, unobstructed flow of air to allow for proper cooling of the engine and water pump head.

Never place the water pump immediately adjacent to a building or other structure – allow at least 2 metres clearance.

Do not run the water pump in close proximity to other heat-generating equipment, such as a water pump. The combined heat that is generated may raise air temperature in the immediate area and there will not be adequate cooling ventilation.

Do not allow debris to accumulate and block airflow.

Do not operate with a tarp, blanket, or cover surrounding the water pump.

|   |  |
|---|--|
| <br><b>WARNING</b> | <b>Heat build up from inadequate ventilation can result in fire, posing a serious risk to nearby persons and structures. Situate so there is adequate clearance around the water pump to allow for cooling airflow so that heat does not build up.</b> |
|---|--|

### **HOT EXHAUST CLEARANCE**

Make sure your water pumps exhaust system is at least 2 meters from all combustibile materials and buildings/structures.

Equip the engine with a spark arrestor if the water pump will be used near any ignitable forestry, brush, bush or grassy land. (see the “Specifications” section of this manual to determine if your water pump is already equipped). Make sure you comply with applicable local, state and federal codes. Keep a fire extinguisher rated “ABC” nearby. Keep it properly charged and be familiar with its use.

### **OPERATE AWAY FROM DUST/DIRT**

Do not use the water pump in extremely dusty or dirty conditions. Excessive dust and dirt can cause premature failure of the machine.

### **HEARING PROTECTION**

Water Pumps can product noise levels >70dB in close proximity, which can be dangerous to human hearing with prolonged exposure to the running water pump for an extended period of time.

|   |   |
|---|---|
| <br><b>WARNING</b> | <b>Never attempt to attach ductwork to the muffler system to lower noise levels. This could cause hot air deflection, heat build up and increased exhaust back pressure, resulting in possible exhaust leakage to damage to the water pump.</b> |
|---|---|

### **An Important Message about Temperatures**

Your water pump is designed and rated for continuous operation at ambient temperatures up to 40 degrees Celsius. When your water pump is needed, it may be operated at temperatures ranging from -15 degrees Celsius to 50 degrees Celsius for short periods. If the water pump is exposed to temperatures outside this range during storage, it should be brought back within this

range before operation. In any event, the water pump must always be operated outdoors, in a well-ventilated area and away from doors, windows and other vents.

#### **INSTRUCTIONS TO OPEN PACKAGE**

1. Please ensure that the machine is in the upright position.
2. Please check that all the relevant booklets are included, namely the Packing List, the Operator's Manual and Warranty Manual. Please then ensure that the products packaged in the box are in accordance to the packing list.
3. This Water Pump is of the highest quality. In the unlikely event of you incurring problems with this machine, please contact Gentech Industries for assistance.

Please see the relevant details below:

Gentech Industries: [customercare @maxwatt.com.au](mailto:customercare@maxwatt.com.au)

#### **PRODUCT STRUCTURE AND DESCRIPTION**

##### **1. Structural diagram of water pump (Fig 1)**



- (1) AIR CLEANER
- (2) MUFFLER
- (3) CARBURETOR
- (4) OIL DIPSTICK
- (5) FUEL TANK
- (6) PUMP

## 2. Operating environment and structure description

The water pump is designed to convey/pump fresh water of normal temperature, OR water of which the quality conforms to GB5084 with a temperature of less than 40 degrees Celsius.

This is an axial suction, horizontal, coaxial direct type centrifugal water pump. The impeller is semi-open or closed. The pump is single stage or multistage and single suction.

The pump body is volute type and the discharge is placed upwards. The pump suction and discharge is a threaded or rapid joint connection.

The mechanical seal is applied to the pump shaft seal. The rotary direction of the water pump is anti-clockwise if viewed from the direction of the pump suction.

### MAIN PARAMETERS

|        | Model  | <b>MXWP20</b> | <b>MXWP30</b> |
|--------|--|---------------|---------------|
| Pump   | Suction/discharge diameter (mm)                  | 50/50         | 80/80         |
|        | Flow rate of specified point (m <sup>3</sup> /h) | 28            | 55            |
|        | Maximum lift (m)                                 | 30            | 30            |
|        | Suction lift (m)                                 | 7             | 7             |
|        | Self-priming time (s)                            | 180           | 180           |
| Engine | Supporting power model                           | AP170F        | AP170F        |
|        | Displacement (ml)                                | 208           | 208           |
|        | Max .Output (kW)                                 | 4.2           | 4.2           |

## USE AND OPERATION

### 1. Preparation and inspection before use

To ensure your safety as well as the maximum lifespan of your water pump, please read below.

- A Please check that each bolt is tight before operating your water pump as some of them may become loose due to the vibration of the water pump whilst in use. Replace any missing bolts immediately.
- B Check your oil level and re-fill if necessary, prior to starting your water pump.
- C Check the water pump for any possible oil leaks. Do not operate the water pump should a leak be noticed.
- D Check that your water pump has sufficient fuel. If necessary, refill before using your water pump.

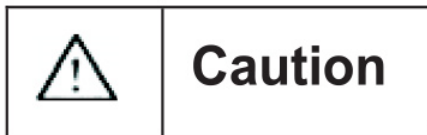

**PLEASE NOTE THAT YOUR WATER PUMP DOES NOT COME WITH SUFFICIENT OIL FROM THE MANUFACTURER. PLEASE DO ENSURE THAT THE WATER PUMP HAS SUFFICIENT OIL BEFORE STARTING AND USING THE MACHINE.**

### 2. Installation of water pump (See Fig 3 – Fig 10)

- (1) Filter
- (2) Pipe joint connection
- (3) Pipe joint
- (4) Pipe joint gasket
- (5) Water inflow/outflow rubber hose
- (6) Clamp



Fig. 3

(1) Connect the filter

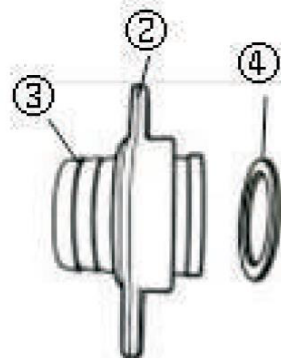

Fig. 4

(2) Assemble the pipe joint

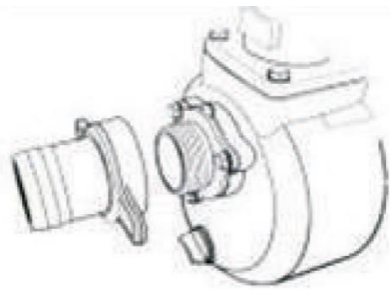

Fig. 5

(3) Install the water suction

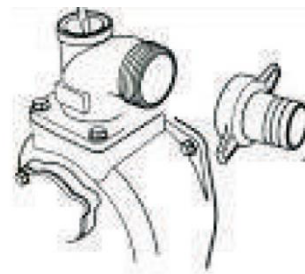

Fig. 6

(4) Connect the water discharge

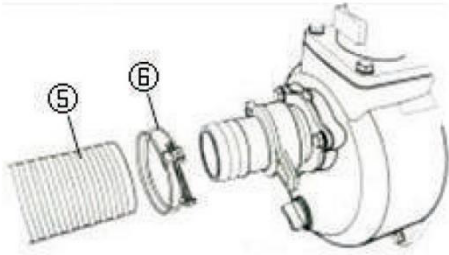

Fig. 7

(5) Connect the water suction pipe

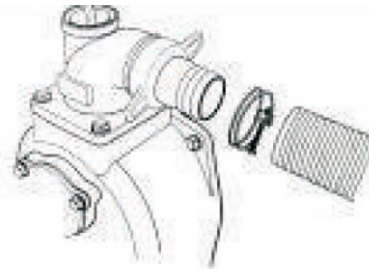

Fig. 8

(6) Connect the water discharge pipe



Fig. 9

(7) Prior to each use, please fill with water. Unscrew the rubber plug and fill the pump body with clean water.

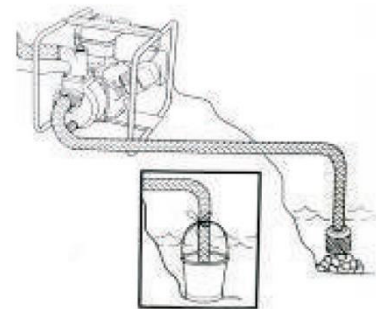
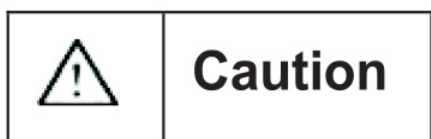

Fig. 10

(8) Place the filter into water and ensure that the water level exceeds 20cm above the the filter. We recommend that you place the filter screen in a bucket or on a rock to avoid mud causing blockages.



The water suction pipe must be a continuous and unfolding structure. Its length should not exceed the required length. To ensure maximum performance from your water pump, we recommend that your water pump is located as close to the point of suction as possible.

Select your water pipe in accordance to your conditions and model. To ensure your safety, the pressure bearing capacity of the water pipe should not lower than the requirements listed in Chapter 4.

Do not operate beyond the lift of your water pump. If there is a decrease of water discharge flow cause by excessive lift, the liquid in the water pump may overheat and cause damage to the seals.

To prevent any air leakage and/or water discharge, ensure that you fasten the pipe joint and pipe coupling clamp sufficiently. Any leakage will reduce the performance and self-priming capacity of your water pump.

To not attempt to operate your water pump without water. This will cause the water pump to overheat and damage the seals.

### **3. Start up and shutdown of the water pump**

Please refer to the engine specifications of your water pump when you switch on or off.

### **4. Maintenance after shutdown**

When turning your water pump off, remove the water suction and discharge pipes, and then unscrew the rubber plug of the discharge outlet (see Fig 1).

Drain away the residual water in your water pump. Wait for your water pump to cool down completely before trying to move it.

## **REPAIRS AND MAINTENANCE**

Periodic inspection and services to your water pump is imperative to maximise its longevity and performance.



- A We recommend that you contact Gentech Industries to facilitate any services or warranty requirements that you may have.
- B Do not attempt to carry out any maintenance on your water pump whilst it is still in use. Always ensure that your water pump has cooled down sufficiently prior to touching it.
- C Smoking or any fire is extremely dangerous when using or repairing your water pump. Do not be negligent.
- D Do not attempt to pump salt/sea water or any water with high acidity through your water pump as this will cause extensive damage and will not be covered by your limited warranty policy.

Refer to the engine section in this manual for any further assistance regarding repairs and maintenance to your water pump.

**PERIODIC MAINTENANCE TABLE**

| MAINTENANCE PARTS                            | DAILY | EVERY 20 HOURS | EVERY 50 HOURS | EVERY 100 HOURS | EVERY 200 HOURS |
|--|-------|----------------|----------------|-----------------|-----------------|
| Clean Water Pump and Check All Nuts an Bolts | *     |                |                |                 |                 |
| Check and Refill Engine Oil                  |       | *              |                |                 |                 |
| Replace Engine Oil                           |       | initial        | *              |                 |                 |
| Clean and Adjust Spark Plug and Electrodes   |       |                | *              |                 |                 |
| Replace Spark Plug                           |       |                |                | *               |                 |
| Clean Air Filter                             |       |                | *              |                 |                 |
| Replace Air Filter Element                   |       |                |                | *               |                 |
| Clean Fuel Strainer                          |       |                | *              |                 |                 |
| Replace Fuel Strainer                        |       |                |                | *               |                 |
| Remove Carbon from Cylinder Head             |       |                |                |                 | *               |
| Clean and Adjust Valve Clearance             |       |                |                | *               |                 |
| Clean and Adjust Carburetor                  |       |                |                |                 | *               |
| Replace Fuel Lines                           |       |                |                | *               |                 |

**TROUBLE SHOOTING**

1. Common water pump faults and trouble shooting

| Fault                                      | Possible Cause  | Remedial Action   |
|--|---|---|
| <b>No water output from the water pump</b> | Inadequate priming in pump                            | Unscrew the threaded rubber plug and add adequate priming   |
|  | Filter blockage                                       | Try to clear the blockage   |
|  | Water suction does not sink into the water            | Adjust the position of water suction so that the water suction is completely submerged into water |
|  | Leakage of water suction pipe                         | Repair the leakage or replace the water suction pipe  |
|  | The installation height of the water pump is too high | Decrease the installation height of the water pump  |
|  | Filter blockage                                       | Try to clear the blockage   |



|                                    |   |  |
|------------------------------------|---|--|
| <b>Low flow rate of Water Pump</b> | Leaking of the water suction pipe   | Repair the leak or replace the water suction pipe  |
|                                    | The installation height of the water pump is too high   | Decrease the installation height of the water pump   |
|                                    | The installation height of the water discharge is too high, or the water discharge pipe is too long | Decrease the height or length of the water discharge   |
|                                    | The water discharge pipe has a sharp bend in it   | Avoid/remove the sharp bend of water discharge pipe  |
| <b>Abnormal Vibration</b>          | Cavity erosion of the water pump  | Decrease the installation height and keep the water suction pipe unobstructed without blockage |

If the aforementioned advice does not resolve your problem, or if what you are faced with is not mentioned in the aforementioned table, please contact Gentech Industries for assistance.

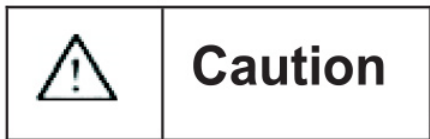

The limited warranty terms and conditions does not cover your water pump if it is disassembled and/or assembled by a non-approved service agent.

For more information, please consult your warranty policy or contact Gentech Industries.

#### **TRANSPORTATION AND STORAGE**



- A To avoid the possibility of a fire, please wait until your water pump has cooled down completely prior to storing it in a confined place.
- B Always ensure that your water pump is transported in the upright position.

**TIPS TO FOLLOW WHEN STORING YOUR WATER PUMP FOR LONG PERIODS OF TIME:**

- A Clean your water pump thoroughly and properly.
- B To avoid dampening the impeller of your water pump, flush the unit properly with clean water to remove any mud and other sediments. Before doing this, ensure that the drain plug has been removed.
- C Empty the fuel tank.
- D Replace with clean engine oil.
- E Slowly pull the starter handle until you feel pressure.
- F Clean the water pump surface and store in a dry place.
- G` Cover the water pump for dust protection.

## **WARRANTY INFORMATION**

### **2 YEAR TRADE WARRANTY**

This warranty is provided by Gentech Industries PTY LTD.

#### **Express Warranty**

Subject to the exclusions set out below, we warrant that this product will be free from defects in materials or workmanship for 24 months from the date of purchase.

The benefits conferred by this warranty are in addition to all rights and remedies which you may be entitled to under the Australian Consumer Law and any other statutory rights you may have under other applicable laws. This warranty does not exclude, restrict, or modify any such rights or remedies.

#### **Warranty Exclusions**

This express warranty does not apply where a defect or other issue with the product is caused by normal wear and tear, misuse or abuse of this product.

#### **Consumer Guarantees**

Our goods come with guarantees that cannot be excluded under the Australian Consumer Law. You are entitled to a replacement or refund for a major failure and for compensation for any other reasonably foreseeable loss or damage.

You are also entitled to have the goods repaired or replaced if the goods fail to be of acceptable quality and the failure does not amount to a major failure.

#### **LIMITED WARRANTY POLICY:**

“This is a **“walk in”** warranty policy and is limited to the range of water pumps specified herein”. We recommend that you take the water pump to the nearest service agent for assistance. Please visit [www.maxwatt.com.au](http://www.maxwatt.com.au) for more information.

#### **To qualify for this warranty:**

“The warranty applies to the first purchaser and each subsequent owner during the applicable warranty time period”.

#### **What the appointed Service Agent will repair or replace under warranty:**

“The appointed Service Agent will repair or replace, at its sole discretion, any part that is proven to be defective in material or workmanship under normal use during the applicable warranty time period. Warranty repairs will be made without any charge for parts and labour. All parts replaced will be considered as part of the original product and the warranty on such parts will expire coincident with the original product warranty”.

## WARRANTY PROCEDURES:

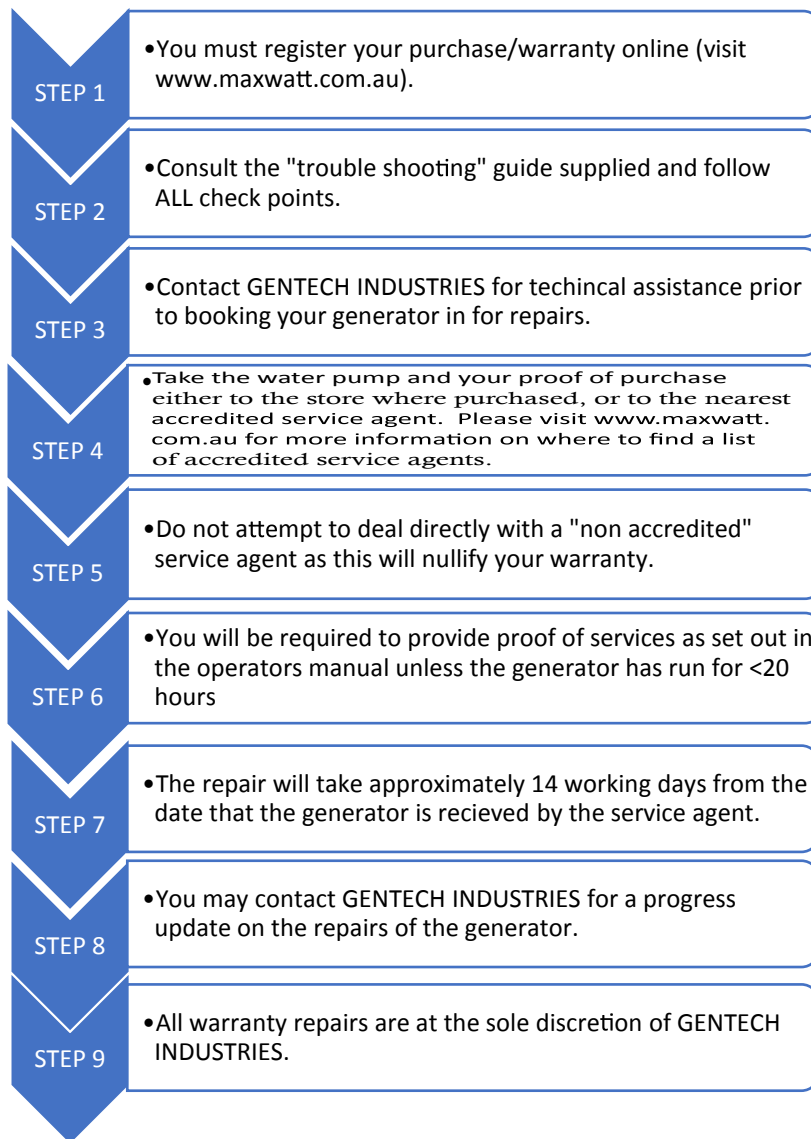

## BELOW IS A LIST OF WATERPUMPS THAT ARE COVERED UNDER THIS WARRANTY:

| MODELS                            | WARRANTY PERIOD<br>PRIVATE/RESIDENTIAL | WARRANTY PERIOD<br>COMMERCIAL/RENTAL |
|-----------------------------------|--|--------------------------------------|
| <b>MAXWATT<br/>ALL<br/>MODELS</b> | 24 months                              | 24 months                            |

**EXCLUSIONS TO THIS LIMITED WARRANTY INCLUDE:**

1. Neglect in the periodic maintenance as specified in the owner’s manual.
2. Improper repairs or maintenance including any repairs and or maintenance carried out by a non-accredited service agent.
3. Operating methods other than those indicated in the owner’s manual.
4. The use of non-genuine parts and or accessories other than those supplied by an accredited service agent.
5. Normal wear and tear including but not limited to the fading of painted or plated surfaces.
6. Consumable parts including but not limited to keys, spark plugs, fuel and oil filters, recoil starter ropes, wheels, lubricants, oil grease and fuel.
7. Cleaning adjustments and normal periodic maintenance work including but not limited to cleaning of the battery, carburettor, engine oil, fuel tank and injectors.
8. Correct preparation when using the water pump for the first time as set out in the owner’s manual.
9. Fire damage as a result of but not limited to overloading, incorrect installation, incorrect re-fuelling and any other causes as set out in the owner’s manual.
10. Damage to any electronic and or electrical appliances connected to the water pump.

**BELOW IS A TABLE OF PARTS THAT ARE LIMITED BY THIS WARRANTY**

| <b>PART</b>            | <b>OUT OF BOX FAILURE</b> | <b>&lt; 20 RUNNING HOURS</b> |
|------------------------|---------------------------|------------------------------|
| <b>STATOR</b>          | *                         |                              |
| <b>ROTOR</b>           | *                         |                              |
| <b>CIRCUIT BREAKER</b> | *                         |                              |
| <b>AVR</b>             | *                         |                              |
| <b>IGNITION COIL</b>   |                           | *                            |
| <b>SPARK PLUG</b>      |                           | *                            |
| <b>BATTERY</b>         |                           | *                            |
| <b>WHEELS AND AXLE</b> |                           | *                            |
| <b>HANDLES</b>         |                           | *                            |
| <b>RECOIL STARTER</b>  |                           | *                            |

**\*NOTE:**

**OUT OF BOX FAILURE REFERS TO A MACHINE THAT HAS RUN FOR < 20 MINUTES.**

## **DISCLAIMER OF CONSEQUENTIAL DAMAGE AND LIMITATION OF IMPLIED WARRANTIES**

Gentech Industries PTY LTD disclaims any responsibility for the loss of time or use of the product, transportation, commercial loss or any other incidental or consequential loss or damage. Any implied warranties are limited to the duration of this written limited warranty policy and procedures manual.

## **ONLINE ORDER RETURNS POLICY**

If you believe an item is faulty, you may have rights to a remedy under the Australian Consumer Law. The Australian Consumer Law does recognize that the relevant time period may vary by product (or service) depending on the nature of the goods (or service), the price paid and any representations made about the goods (or service).

Where you believe an item is faulty, it may be necessary for us to send your goods to the manufacturer or their service agent for it to be assessed within a reasonable period of time. If there is a major failure with the item, you may choose a refund, exchange or repair. If the failure is minor, we will repair the item (or, at our discretion, we may replace the item) within a reasonable time.

Where an item is damaged through misuse or abnormal use, the manufacturer cannot provide a refund, exchange or repair.

Gentech Industries PTY LTD require satisfactory proof of purchase before providing a remedy under the Australian Consumer Law.

## **DAMAGED IN TRANSIT**

Please do not sign for the delivery of goods that are obviously damaged. If damage is only found upon unpacking, then please contact the store that fulfilled your order as soon as possible. Store contact details can be found on your order confirmation email. They will then arrange for the goods to be collected and a refund or replacement item sent out to you. Alternatively, please take the items to your nearest store where they will be able to help you.

## **NOT AS ADVERTISED /INCORRECT ITEM**

If your order arrives and it's not what you ordered, please contact either the store the order came from or on the online support team at [customercare@maxwatt.com.au](mailto:customercare@maxwatt.com.au).

## **FAULTY PRODUCT**

Please contact the store that fulfilled your order. Store contact details can be found on your order confirmation email. The store will need to assess whether the fault is a major or minor fault and will either arrange for the product to be repaired or replaced. Some manufacturers require us to send faulty items to them for assessment before we can give you a replacement.

## **CHANGE OF MIND**

Changed your mind? Don't worry. You've got 30 days to get your order back to the store it was sent from and provided its un-used, we'll give you a refund minus the costs of any shipping.

## **VALID RECEIPT**

A copy of your in-store purchase receipt or online order confirmation email is required for any return. If returning your product to store, please ensure you take a copy with you.

**DISCLAIMER OF CONSEQUENTIAL DAMAGE AND LIMITATION OF IMPLIED WARRANTIES:**

Gentech Industries and all distributors and retailers of the Maxwatt brand disclaim any responsibility for the loss of time or use of the product, transportation, commercial loss or any other incidental or consequential loss or damage. Any implied warranties are limited to the duration of this written limited warranty policy and procedure manual.

